

Specialists in Engineering Solutions for the Recycling and Material Handling Sectors



The Anaconda SR Range of Mobile Tracked Finishing Screens have been developed specifically to suit applications where separating fines is of the utmost importance.

The **SR410** is robust with a high productivity rate as it can screen and stockpile 3 different products at an output of 200TPH. Fully equipped with a 10 x 4 Double Deck Screen, 14ft Feed Hopper, Main Conveyor and 3 hydraulically folding stockpiling conveyors this versatile finishing screen is capable of dealing with any application.

The **SR410** can be set up and running within 20 minutes of delivery. Commissioning is aided with the hydraulic controls to position and guide all the Conveyors, Screen Box and Landing Legs into place.

Anaconda stock a full range of spare parts as a display of our commitment to provide a dedicated and responsive service to all our customers.



Head Quarters:
Anaconda Equipment 'A McLanahan Company',
Ardboe Business Park,
Kilmascally Road,
Dungannon, Co. Tyrone
BT71 5BJ



Contact us :

Tel - +44 (0) 28 86737878
Fax - +44 (0) 28 867 36675
Email - sales@anacondaequipment.com

Specialists in Engineering Solutions for the Recycling and Material Handling Sectors

SPECIFICATIONS AND TECHNICAL DETAILS

Features

- High energy 3m X 1.2m (10'X4') 2 Deck Screen Box
- End tensioned mesh arrangement
- Hopper capacity of 5.8m³
- Screen-box angle adjustment (28°-36°)
- Screen-box walkways for maintenance and mesh change
- Variable Speed 3 ply belt feeder
- Fully adjustable spreader plate for optimum screening
- Variable speed on all stockpile belts

Engine Options

- T3a - JCB444 DieselMAX - 63KW / 85HP
- T3a - Duetz Turbo 2011 - 49.5KW / 66HP

Options

- Screen Decks (Mesh - Piano Wire)
- Remote Tipping Grid
- Radio Remote Control
- Dust Covers
- Anti-Roll Back
- Hopper Extensions

Weight

- 15,500KG

WORKING AND TRANSPORTATION DIMENSIONS

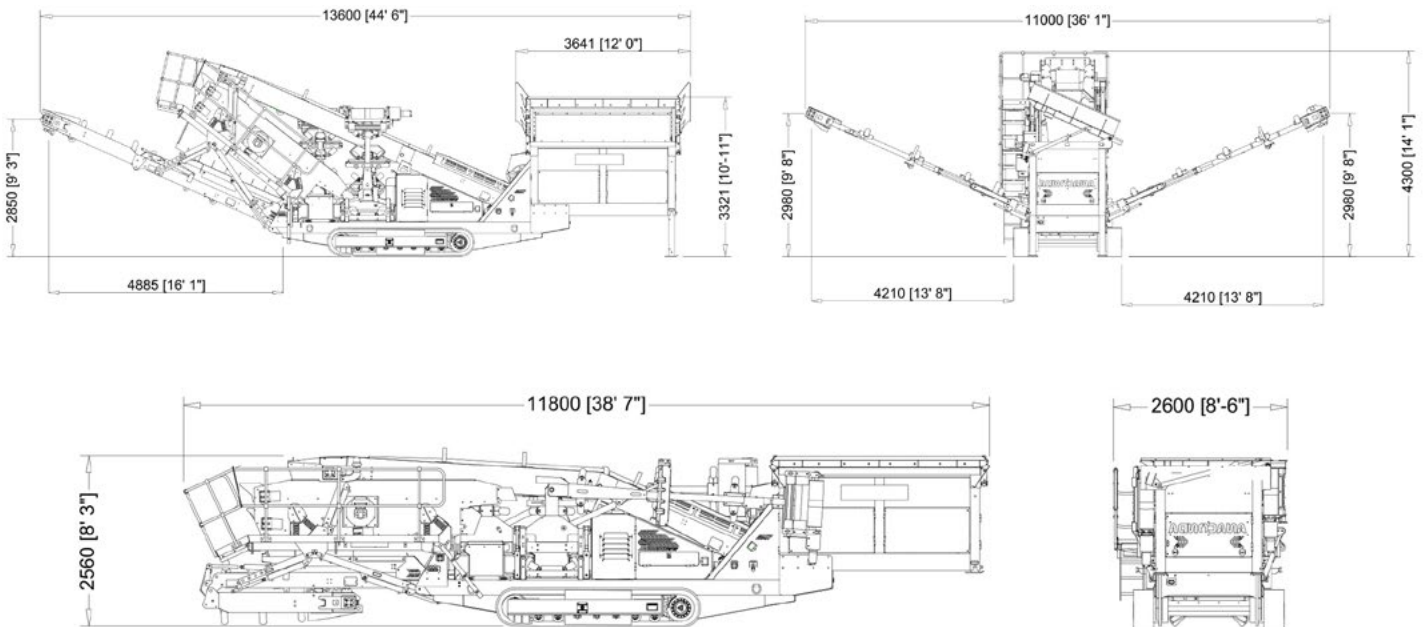

Anaconda sell and distribute our entire product portfolio via a Dealer Network,
For your nearest dealer please contact us or visit our website.

Anaconda reserves the right to make changes to design without reservation and without notification.
Tonnage estimations are dependent on fractions, material type, size and application.

WWW.ANACONDAEQUIPMENT.COM

FOLLOW OUR SOCIAL MEDIA CHANNELS

